

invenSYS  
Foxboro®

Field Devices For

# Measurement & Instrumentation



Analytical

Optimize your plant performance with a reliable partner you can trust

# Foxboro Electrochemical Sensors

Bring us your most difficult electrochemical measurement challenges. We have the intelligent Foxboro® analyzers, transmitters, sensors and solutions you need. Our 50-year analytical history displays an entire galaxy of significant technical firsts. Today, we supply more than just quality instrumentation. Our expert application specialists tackle challenges from feasibility studies for new processes to fine-tuning your existing application. We offer the widest array of innovative sensor technologies, materials, sizes and geometries in the business. From ultrapure water to the most aggressive acids and bases, we can handle your process solution.

“Operator safety is paramount in our facility. We have to find ways to reduce operator exposure to hazardous fluids like strong acids.”



The Foxboro 871FT Flow-through Conductivity Sensor is equipped with a calibration port on the outside of the sensor body. When the sensor needs to be calibrated, you can access the calibration port without breaking the process line, thereby eliminating the risk to your operators from exposure to dangerous fluids.

“We’re being driven to reduce inventory. Unfortunately, when a pH sensor fails, we need a replacement right away. I can’t live with delivery times of 4 weeks or more.”



Foxboro’s factory provides shipment within 24 hours for a long list of measurement equipment, including several types of pH sensors. This service, referred to as “Rocket Delivery”, is provided to our customers at no extra charge. All elements of sensor manufacturing are performed in the Foxboro factory, allowing us to provide rapid delivery and predictable high quality.

“I have to decrease costs associated with maintenance of pH sensors. The constant cleaning and replacement of sensors is eating up our maintenance budget.”

Foxboro pH sensors are designed to reduce maintenance. Our patented DolPHin® sensor provides a Nafion ion barrier which protects the internal reference electrode and reduces clogging of the outer junction due to silver ion migration. Its nonmetallic solution ground allows for sensor diagnostics and provides excellent chemical compatibility. Its unique glass pH electrode provides long life in high temperature and temperature cycling applications. All of these design features have been carried through to our new 12mm PH12 sensor as well.



*“We can now complete a pH adjustment in 3 hours rather than the 18 to 24 hours it previously took.”*

Senior Technical Supervisor  
Gilead Sciences



“ We have some very aggressive chemicals where we need to measure conductivity and concentration. Most of the sensors we have tried only last a few months before they fail due to chemical attack from the process. ”

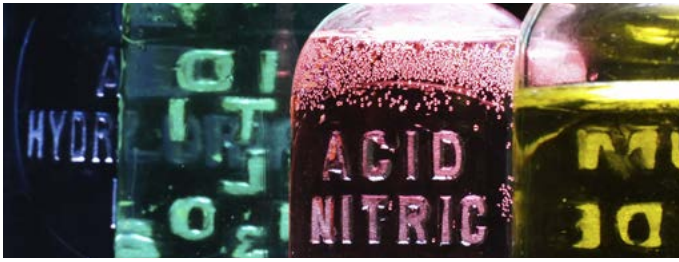

Foxboro offers the broadest range of electrodeless conductivity sensors on the market. Our PEEK body sensors use a proprietary sealing technique that eliminates the need for internal seals. With no metallic wetted parts, the PEEK sensors do not suffer from leakage due to different coefficients of thermal expansion, a weakness often seen in other suppliers' sensors.



“ I'd like to be able to tell when the pH or reference electrode is in need of maintenance, before it is too late. ”

Foxboro's 875PH and 876PH Analyzers are equipped with a host of diagnostics for pH sensors. In addition to failure diagnostics, these analyzers include predictive diagnostics for reference fouling, low slope and electrode aging. By monitoring these diagnostics, the pH sensor can be scheduled for maintenance before failure occurs.



“ Analytical measurements are a problem for us because we don't have our own experts. I am looking for a partner who can provide reliable technical support and help us select the correct equipment for the application. ”

Foxboro's Technical Assistance Center is staffed 24/7 with experts in analytical products and applications. We also have an analytical laboratory where we can accept customer samples to perform analyses such as conductivity temperature compensation profiling.



# Success stories commercial benefits

## Our pH sensors cut costs & optimize operations at Eastman Chemical company

*"Eastman's equipment and maintenance costs were eight times lower than with previous sensors, and efficiency of our scrubber operation was optimized."*

**Wyatt Partney Senior Control Systems Technician**

### Customer Challenge

- Existing sensors had to be replaced every 2 weeks-often 3 times a week. Inaccurate readings meant unacceptably high manufacturing and maintenance costs

### Solution

- Foxboro DolpHin pH sensors

### Customer Benefits

- New sensors gave improved stability, accuracy, performance with up to fivefold increase in sensor response speed while measuring 8.8 million pounds of chemicals per day
- Our pH glass formulation increased sensor life to six months; this longevity reduced equipment and related maintenance/replacement costs eightfold
- Increased accuracy also meant operators reduced caustic, slashing caustic use levels by a remarkable 50%



Chemical industry

## Foxboro 871PH sensor improves pharmaceutical product, process and profits for Raylo Gilead

*"We found many vendors offered quality sensors, Foxboro was the only one that could provide a robust design that could stand up to all the reagents and solvents in our solutions."* **Rob Pastushak Snr Technical Supervisor of Pharmaceutical Manufacturing**

### Customer Challenge

- Improve efficiency of manufacturing process, specifically pH measurement in caustic solutions, without impacting company bottom line

### Solution

- Foxboro 871PH Sensor

### Customer Benefits

- Accurate pH measurement in demanding application, accurate to  $\pm 0.03$  pH units
- cGMP and FDA compliance & certification
- Less time for pH adjustment, three hours rather than the 18 to 24 it took before
- Less sampling - no longer need 40 samples to confirm measurement accuracy, only one is needed now, as a matter of quality assurance protocol



Pharmaceutical industry

## Foxboro conductivity sensing sparks automated, efficient biodiesel fuel processing

*"..Conductivity sensing is really ideal for this application. A conductivity measurement system is relatively inexpensive, very clean, and maintenance free. We brought in Invensys to discuss its Foxboro products and decided these were the solutions we needed."*

**Scott Nisula Chief Technical Officer Delta BioFuels Inc**

### Customer Challenge

- To ensure that the production process of Delta BioFuel's biodiesel would not be interrupted during the fuel separation process. Sustainable alternative energy sources demands an immediate technology solution that would produce a very pure biodiesel product quickly and efficiently

### Solution

- Foxboro 871EC Series Electrodeless Conductivity Sensors

### Customer Benefits

- The 871EC sensor enabled production of between 80-100 million gallons of biodiesel per year, making it one of the largest biodiesel plants in the country
- Delta BioFuels achieved the production goals of its four 20,000-gallon reactors and controls the delicate separation process through accurate conductivity measurements
- By implementing a reliable and accurate process automation system, Delta BioFuels has been able to eliminate human error and enhance overall product quality



BioFuels industry

# Real-world applications

## Chemical Industry: Sulfuric Acid Production benefits with our conductivity sensor/analyser

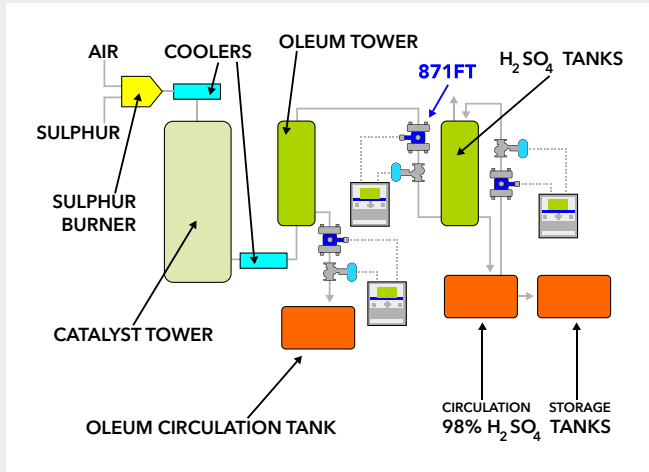

Producing sulfuric acid is a particularly demanding application. The closer you come to 100 percent, the more difficult it is to accurately measure acid strength: The higher the strength of sulfuric acid, the greater its market value. The Electrodeless sensor design significantly minimizes the difficulties of build-up of process material. This provides an invasive sensor of extraordinary integrity, which is robust even in this aggressive application. This means improved process efficiency and lower production expenses plus reduced material and maintenance costs. In addition, precise and reliable measurement of high-strength sulfuric acid means consistent high-end product quality for improved profitability.

## Pulp & Paper Industry: Paper Machine Wet End pH Control

The demand for upgrading paper quality and uniformity has introduced tougher challenges to on-line sensors with hundreds of hours spent each year cleaning pH sensors in this very aggressive process area. Between the thick consistency stock and the periodic cleaning process, known as a boil-out, pH electrodes typically have a very short life. The Foxboro pH sensor range ensures longer sensor life due to a flat ruggedized pH electrode. A retractable sensor installation isolates the sensor during boil-out. Resistance to coatings allows longer intervals between cleanings and improved maintenance efficiency due to predictive sensor diagnostics such as coated reference or low slope.

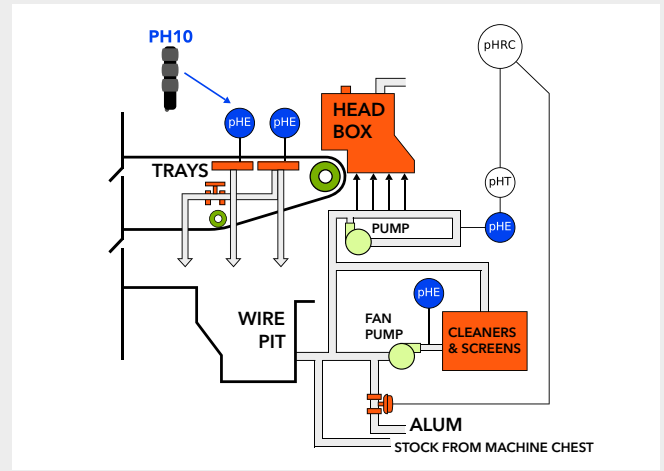

## Power Generation: Recycling Emissions Control by-products with DolpHn pH Sensor

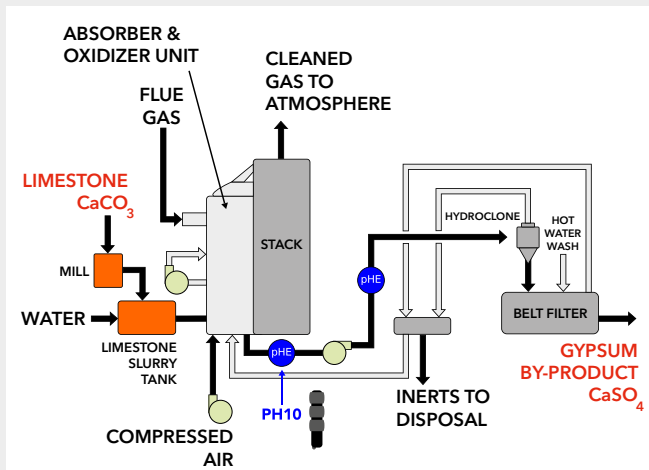

In gypsum production sensors are exposed to thousands of tons of flowing sludge, which is maintained at temperatures of approximately 160°F (71°C). Gypsum forms as a crystalline, abrasive substance, adding additional wear and tear. One power facility tested our rugged pH sensors that can last up to four times longer than conventional sensors, and became one of the first sites in the world to implement a prototype. Other advantages include accurate, reliable pH measurement in demanding applications, improved production and operational efficiency, reduced waste disposal costs for environmental compliance and the extended service life reduces maintenance and materials costs.



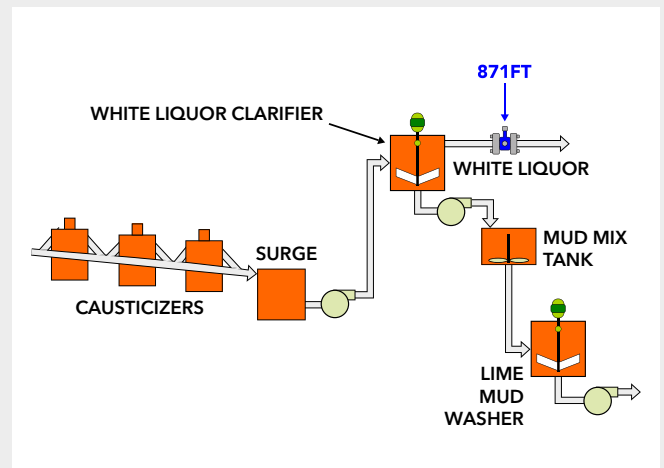

## Pulp & Paper Industry: White Liquor Strength production

The primary measurement challenge is holding tight, temperature-compensated conductivity accuracy as this measurement has a direct effect on white liquor strength which is used as a control parameter in the digester charging process. Inaccuracy will occur due to electrode corrosion, polarization or the conductivity sensor itself can become fouled. Foxboro 871FT offers longer sensor life due to corrosion resistant PEEK material and coating effects are minimized due to the use of electrodeless conductivity technology. Longer intervals between calibrations are possible and they are faster and safer due to the built-in calibration port. In addition improved accuracy is possible due to optimized temperature compensation.







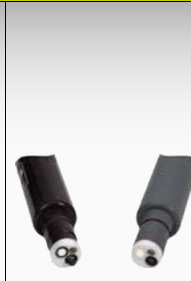
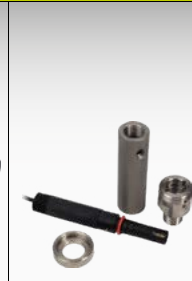

# Selection guide

## Foxboro pH and ORP Electrochemical Sensors

						
<b>Model</b>	<b>PH DolpHin</b>	<b>ORP10 DolpHin</b>	<b>PH12</b>	<b>871A</b>	<b>871PH</b>	<b>EP462A</b>
Sensor Type	pH	ORP	pH/ORP	pH/ORP	pH/ORP	pH low conductivity
pH Range	0 - 14	N/A	0 - 14	2 - 12	0 - 14	0 - 14
Max Temperature	121 C	121 C	140 C	85 C	121 C	100 C
Installation Type	Universal slip fit, Submersion, In-line, Retractable	Universal slip fit, Submersion, In-line, Retractable	PG13 connection to accessories, In-line, Retractable	Submersion, In-line, Retractable	Submersion, In-line, Retractable	Twist-lock, Submersion, In-line, Retractable
Electrode Type	Domed or flat	Flat	Domed or flat	Flat	Selectable	Domed
Maintenance Type	Disposable	Disposable	Disposable	Disposable	Rebuildable	Disposable
Integral Pre-amp	Yes	Yes	No	Yes	Yes	No
Features	High performance	High performance	12mm form factor, available lengths 120mm - 425mm	Totally flat sensing surface	Small, inexpensive plug-in electrodes	Stable measurements in high purity water

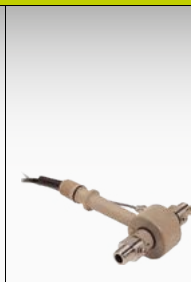
## Foxboro Electrodeless and Flowthrough Conductivity Electrochemical Sensors

						
<b>Model</b>	<b>871EC</b>	<b>EP307B</b>	<b>EP307G</b>	<b>871FT</b>	<b>EP402</b>	<b>FT10</b>
Sensor Type	Small and large bore	Barrel geometry	Borosilicate glass	Flowthrough	Flowthrough	Flowthrough
Installation Type	Invasive, Insertion, Immersion, Retractable	Invasive, Insertion, Immersion, Retractable	Invasive, Insertion, Submersion	Non-invasive, In-line, Sanitary tri-clamp, Industrial flange	Non-invasive, In-line, Threaded	Non-invasive, In-line, Flaretek tube, NSP300 tube
Line Size	3" min	3" min	3" min	0.5 to 4"	3/32 to 5/8"	1/2, 3/4 and 1"
Calibrate In-line	No	No	No	Yes	Yes	Yes
All Thermoplastic	Yes	Yes	No	No	No	Yes

# Selection guide

## Foxboro Contacting Conductivity and Resistivity Electrochemical Sensors



**871CR**

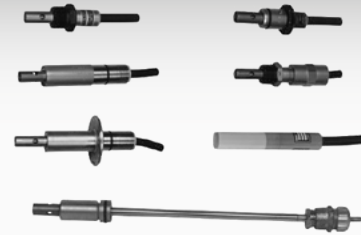

**871CC**

<b>Model</b>	<b>871CR</b>	<b>871CC</b>
<b>Mounting</b>	Insertion, Immersion, Retractable	Insertion, Immersion, Retractable
<b>Installation Type</b>	Universal slip fit	Fixed installation type dictated by model code selection
<b>Temperature Compensation</b>	1000 ohm 3-wire platinum RTD	100 ohm 2-wire platinum RTD or 100 kohm 2-wire thermistor
<b>Accuracy</b>	0.1 % of 0.1 cm-1 cell factor	2 % of 0.1 cm-1 cell factor
<b>Insertion Lengths</b>	Model code selectable	Fixed length

## Foxboro Transmitters

<b>Model</b>	<b>875PH *</b>	<b>876PH</b>	<b>875EC *</b>	<b>876EC</b>	<b>875CR</b>	<b>876CR</b>
<b>Measurements</b>	pH, ORP, ISE	pH, ORP, ISE, Combination pH/ORP	Conductivity, Concentration	Conductivity, Concentration	Conductivity and Resistivity	Conductivity and Resistivity
<b>2 or 4 wire</b>	4-wire	2-wire	4-wire	2-wire	4-wire	2-wire
<b>Power</b>	V ac, 24 V dc	12.8 to 42 V dc	V ac, 24 V dc	14.7 to 42 dc	V ac, 24 V dc	12.8 to 42 V dc
<b>Menu Driven with Help Text</b>	Yes	Yes	Yes	Yes	Yes	Yes
<b>Inputs</b>	1 Sensor, 1 Temp	1 Sensor, 1 Temp Combination pH/ORP	1 Sensor, 1 Temp	1 Sensor, 1 Temp	2 Sensor, 2 Temp	1 Sensor, 1 Temp
<b>Alarms</b>	2	0	2	0	2	0
<b>Safety Certs</b>	Class 1, Div 2 Non- incendive	Class 1, Div 1 and 2 Intrinsically safe	Class 1, Div 2 Non- incendive	Class 1, Div 1 and 2 Intrinsically safe	Class 1, Div 2 Non- incendive	Class 1, Div 1 and 2 Intrinsically safe
<b>Output</b>	Dual 4 - 20 mA, HART	4 - 20 mA, HART	Dual 4 - 20 mA, HART	4 - 20 mA, HART	Dual 4 - 20 mA, HART	4 - 20 mA, HART
<b>Multi-application</b>	-	-	Yes	Yes	Yes	Yes
<b>Custom curve</b>	-	-	Multiple, auto-switching	Multiple, auto-switching	Multiple, auto-switching	Multiple, auto-switching

\* 875CR version shown

Your Foxboro representative:



**i n v e n s y s**<sup>TM</sup>

**Invensys Operations Management**

10900 Equity Drive  
Houston, TX 77041 U.S.A  
1.713.329.1600  
iom.invensys.com

**Invensys Foxboro**

33 Commercial Street  
Foxboro, Massachusetts 02035-2099 U.S.A  
1.866.746.6477 Toll-free within U.S.A  
1.508.549.2424 Global

Invensys, the Invensys logo, ArchestrA, Avantis, DolpHin, Eurotherm, Foxboro Eckardt, Foxboro, IMServ, InFusion, SimSci-Esscor, Skelta, Triconex, and Wonderware are trademarks of Invensys plc, its subsidiaries or affiliates. All other brands and product names may be the trademarks or service marks of their representative owners.

© 2013 Invensys Systems, Inc. All rights reserved. No part of the material protected by this copyright may be reproduced or utilized in any form or by any means, electronic or mechanical, including photocopying, recording, broadcasting, or by any information storage and retrieval system, without permission in writing from Invensys Systems, Inc.

Part No. HA031609. Issue 1. 04/13

[fielddevices.foxboro.com](http://fielddevices.foxboro.com)